

Photovoltaic Module

3HT ELM-80M Series

ELM-80M photovoltaic modules offer industry-leading performance, durability, and reliability for various applications. An anti-reflective coating provides a uniform blue color and increases the efficiency in all weather conditions. Common applications include RVs, cabins, solar power stations, and lighting equipment. Designed to withstand rigorous weather conditions, a junction box is provided for easy electrical connections in the field, making EVERLIGHT modules the perfect choice for advanced technology and reliability.

TYPICAL ELECTRICAL CHARACTERISTICS			
	ELM-80M-1	ELM-80M-2	ELM-80M-3
Power	80W	85W	90W
Max. power	17.5V	17.5V	17.5V
Max. current	4.58A	4.87A	5.11A
Open-circuit voltage	21.7V	21.7V	21.8V
Short-circuit current	5.12A	5.44A	5.50A
Temperature coefficient of I_{sc}	$(0.065 \pm 0.015) \% / ^\circ C$		
Temperature coefficient of V_{oc}	$-(160 \pm 20) mV / ^\circ C$		
Temperature coefficient of power	$-(0.5 \pm 0.05) \% / ^\circ C$		
Rated voltage	1000V		
Operating temperature	$-40 / +85 ^\circ C$		
	227g steel ball down from 1m height and 60m/s wind		

PERFORMANCE			
	ELM-80M-1	ELM-80M-2	ELM-80M-3
Power	80W	85W	90W
Efficiency	$\pm 5\%$	$\pm 5\%$	$\pm 5\%$
Open-circuit voltage	15.0%	15.9%	16.8%
Rated voltage	12V	12V	12V
	Pm is not less than 90% in 10 years and 80% in 25 years		

MECHANICAL CHARACTERISTICS	
Dimensions (mm)	1204×545×40
Thickness	$\pm 3mm$
Weight	7.5
	Clear anodised aluminium alloy type 6063T6. Silver Universal frame.
	36 cells (125 x 125mm) configured geometrically in a 9 x 4 matrix connected in series.

Conditions: @STC 1000W/m², AM1.5, 25°C

Certifications: CE certified, TÜV according to IEC 61215 expected by Oct. 2007.

Module Diagram

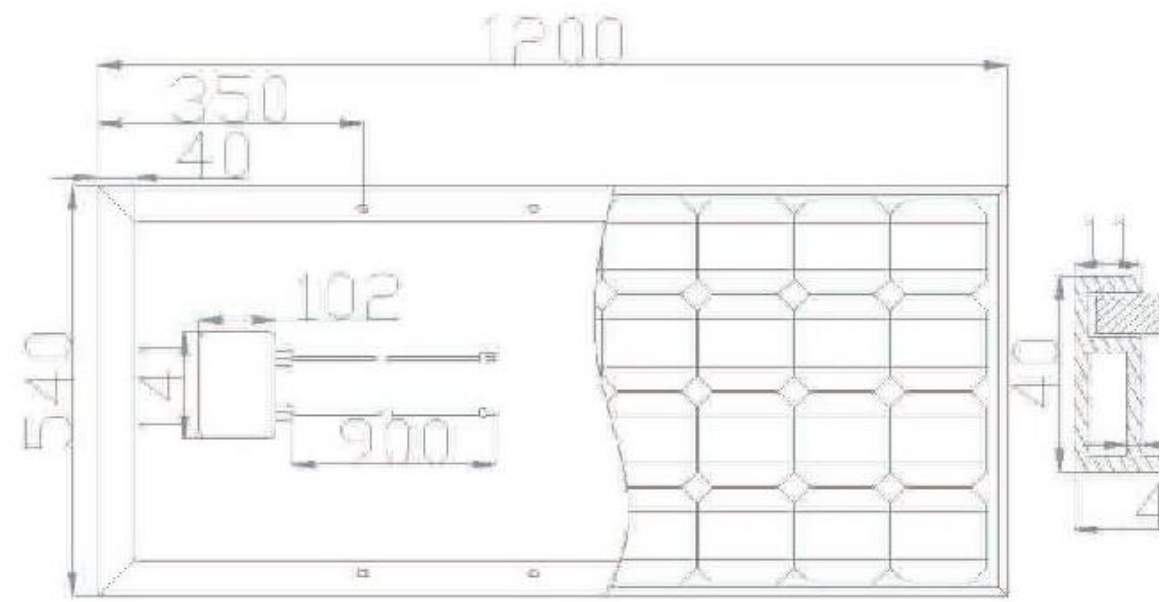

Graph